

Safety Products



**NEW! Bil-Guard® 2.0 Hatch
Safety Railing System**



LadderUP® Safety Posts

Bilco®

Introducing the **NEW**

Bil-Guard® 2.0

Hatch Safety Railing System



*Bil-Guard 2.0 shown on
Type S-20 3'0" x 2'6" roof hatch
Patented and patent pending*

Stronger. Simpler. Better.

Now Featuring Corrosion-Resistant Aluminum Rails

Product Features

- Meets and exceeds OSHA 29 CFR 1910.23
- Non-penetrating attachments; quick and simple installation with standard tools
- Corrosion-resistant aluminum rails and mounting brackets, along with stainless steel hardware, are ideal for any climate
- Safety yellow powder coat paint finish
- Self-closing and locking gate
- Fits all brands of roof hatches with capflashing
- Available in standard and custom sizes



Stainless steel spring hinges
and self-closing gate



Automatic gate latch with interior
and exterior release
patent pending



Pivoting post mounting brackets



LadderUP® Safety Post

LadderUP® Safety Posts provide easier, safer ladder access through roof scuttles, floor, vault, and sidewalk doors, and manholes. This telescoping post permanently mounts to the top two rungs of any fixed ladder, providing a positive hand-hold and enabling the user to enter or exit an opening in an upright and balanced position.



Standard Features and Benefits:

- Adjustable mounting hardware accommodates virtually any ladder rung size or spacing
- Telescoping design is spring balanced for ease of operation
- Automatically locks in the fully raised position to provide the user with a firm and steady hand-hold
- Handy release lever allows the post to be easily lowered to its retracted position
- Available in four levels of corrosion resistance to provide many years of trouble free, dependable service



Installs easily on any fixed ladder

Safety Products

NEW! Bil-Guard® 2.0 Hatch Safety Railing System

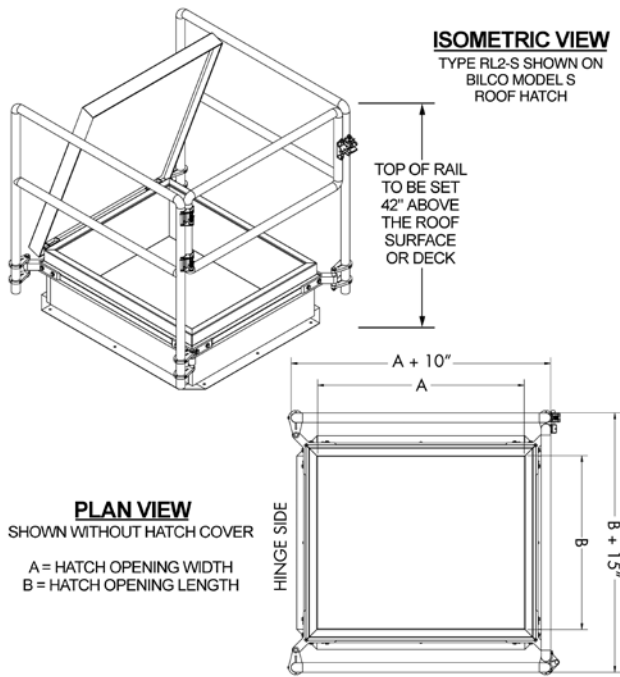

Specifications

Posts and rails are 1 1/4" schedule 40 pipe in 6061 T6 aluminum alloy. Curb mounting brackets and teardrop brackets are 6063 T5 aluminum extrusion. Locking mechanism is cast aluminum and spring hinges and all fasteners are type 316 stainless steel. Hatch rail system satisfies the requirements of OSHA 29 CFR 1910.23 and meets OSHA strength requirements. Finish shall be safety yellow powder coat paint finish. Manufacturer shall provide a 5-year warranty against defects in material and workmanship.

Standard Sizes and Weights

The Bil-Guard 2.0 Hatch Safety Railing System is designed to fit all brands of roof hatches with capflashing. The table below provides railing system models and weights and includes standard Bilco roof hatch sizes and model numbers for easy cross-reference.

ROOF HATCH SIZE (width x length)		ROOF HATCH MODEL	BIL-GUARD 2.0 MODEL
inches	mm		
36 x 30	914 x 762	S	RL2-S
36 x 36	914 x 914	E	RL2-E
48 x 48	1219 x 1219	F	RL2-F
30 x 54	762 x 1372	NB	RL2-NB
30 x 96	762 x 2438	L	RL2-L

Special sizes available. Contact Bilco for more information.

LadderUP® Safety Posts

Specifications

Install on fixed ladder(s) below hatch cover(s), LadderUP® safety post Model ___ as manufactured by The Bilco Company. Device shall be (refer to chart for material/finish* of model specified). It shall be designed with a telescoping tubular section that locks automatically when fully extended. Upward and downward movement shall be controlled by a stainless steel spring balancing mechanism. Unit shall completely assembled with fasteners for securing to the ladder rungs in accordance with the manufacturer's instructions. * If installation is to be in corrosive atmosphere, specify Model LU-2, LU-3 or LU-4 as conditions warrant.

Standard Sizes and Weights

Model#	Material/Finish	Weight	
		lbs.	kg.
LU-1*	Steel, yellow powder coat	24	11
LU-2	Steel, hot dip galvanized	24	11
LU-3	Type 304 Stainless Steel, sand blast finish	24	11
LU-4	Aluminum, mill finish	14	7

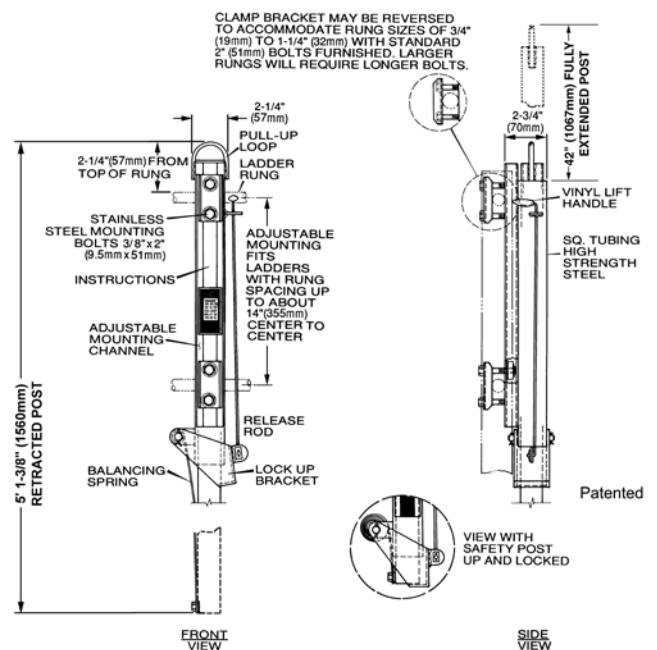

The Bilco Company • P.O. Box 1203 • New Haven, CT 06505
(800) 366-6530 • www.bilco.com • commercial@bilco.com